



PRODUCT MANUAL - THETA ULS

Product Manual

Version 25.03.2024



TABLE OF CONTENTS

1. Thank you for flying ADVANCE	1
2. General safety advice	1
3. Limitations	1
3.1. Handle with Care	2
3.2. Piloting requirements	2
3.3. Suitable harnesses	2
3.4. Weight range	2
3.5. Flying with a wet paraglider (risk of deep stall)	3
3.6. Winching	3
3.7. Acrobatics	3
3.8. Tandem flying	4
3.9. Paramotoring	4
4. Getting Started	4
4.1. Delivery	4
4.2. Basic settings	4
4.3. Speed system	5
5. Flight characteristics	5
5.1. Takeoff	5
5.2. Normal flight	6
5.3. Turning flight	7
5.4. Accelerated flight / C-Handles	7
5.5. Collapses	8
5.6. Rapid descents	9
5.7. Stalling	11
5.8. Landing	12
6. Folding & Packing	12
6.1. Packing basics	12
6.2. Using a inner bag (e.g. COMPRESSBAG)	13
6.3. Using a cellular bag	14
6.4. Using a compression cellular bag	14
7. Maintenance & Care	15
7.1. Storage	15
7.2. Maintenance	15
7.3. Glider inspection	17
7.4. Repairs	18



7.5. Disposal	19
8. Service & Warranty	19
8.1. ADVANCE Service Center	19
8.2. Support (Website)	19
8.3. Online Account	19
8.4. Warranty	19
9. Technical data	20
9.1. Data	20
9.2. Materials	20
9.3. Certification	21
10. Appendix	21
10.1. Components overview	21
10.2. Assembly instructions Softlink	22
10.3. Mounting instructions brake lever	23



1. THANK YOU FOR FLYING ADVANCE

Thank you for choosing an ADVANCE quality product with Swiss engineering.

User manual

This user manual is an important part of your product. You will find instructions for Putting into service and use in practice as well as important information on safety, care and maintenance. We encourage you to read this document carefully before your first flight. Video instructions can be accessed via QR codes if available. All information can be found on our website in the "Download" section.

Download section

Product Registration

Register your new ADVANCE product online in your MyADVANCE account no later than 10 days after purchase for a warranty extension or to be informed promptly by e-mail about updates and safety-relevant findings regarding your product

Product registration

Our story: Pioneering spirit and Swiss precision

Putting our ideas into the air. That's what we can do. For more than 30 years, ADVANCE have kept the needs and wishes of our pilots at the forefront. With Swiss precision we refine model after model. Highest quality and absolute reliability have our top priority, in the air and in our customer service. So from pioneers we have become perfectionists, and a leading worldwide comprehensive service provider.

Questions and support

You can always contact your ADVANCE dealer or our support team, we will be happy to help you. Send an email to support@advance.ch

We wish you many exciting and enjoyable hours in the air with your new product!

2. GENERAL SAFETY ADVICE

Flying a paraglider calls for appropriate training and a sound knowledge of the subject, as well as, of course, the necessary insurance cover and licence. A pilot must be able to correctly assess the weather conditions before taking off. His or her capabilities must be adequate for the actual paraglider. The paraglider pilot is also required bear a sense of responsibility towards the natural world, especially regarding the preservation of wildlife and landscape.

Warning

Wearing an adequate helmet, suitable boots and clothing, and carrying an emergency parachute (a 'reserve') are essential. Before every flight all items of equipment should be checked for damage and airworthiness. A proper pre-takeoff check must also be carried out.

Warning

Every pilot bears sole responsibility for all risks, including injury or death, when participating in the sport of paragliding. Neither the manufacturer nor the seller of a paraglider can guarantee or be held responsible for the pilot's safety.

3. LIMITATIONS



3.1. Handle with Care

The THETA ULS is an ultralight paraglider. The life of this product is highly dependent on your care. Mechanical stresses such as deep spirals, acro manoeuvres, dragging on the ground etc. accelerate the ageing process and should be avoided. A lightweight product is much more sensitive to stress of all kinds.

SIV Overloads

We do not recommend using this lightweight product for SIV training. Excessive loading can cause non-safety-related damage to the product, which is not covered by the ADVANCE guarantee.

3.2. Piloting requirements

The THETA ULS has a EN/LTF B certification and is intended for pilots with several years of flying experience who fly regularly (40 hours or more per year) and already have sufficient thermal flying experience.

An active flying style using brakes, speed system and/or riser control (C-Handles) is required. As the pilot you must be able to recognise canopy disturbances at their onset, and be able to oppose them by means of adequate, appropriate and timely control response. In addition you must be fully familiar with the normal fast descent techniques and be capable of using them when required..

3.3. Suitable harnesses

ADVANCE paragliders are compatible with all ADVANCE harnesses, provided nothing to the contrary is explicitly stated in the paraglider manual. Basically, the THETA ULS may be flown with any harness that does NOT have rigid cross bracing.

During certification testing, harnesses with the following characteristics were used:

- All-up in-flight weight less than 80 kg: carabiner distance 40 ± 2 cm, height 40 ± 1 cm
- All-up in-flight weight 80 to 100 kg: carabiner distance 44 ± 2 cm, height 42 ± 1 cm
- All-up in-flight weight more than 100 kg: carabiner distance 48 ± 2 cm, height 44 ± 1 cm

Warning

A harness and its settings (back angle, carabiner distance, speed bag etc.) can significantly influence the flight behaviour of a paraglider.

3.4. Weight range

The THETA ULS comes in five sizes. The weight ranges for the different wing sizes are listed in the "Technical Data" section. The figures given there refer to total take-off weight. This includes the pilot's body weight including clothing, as well as the weight of all the equipment (paraglider, harness, instruments, etc. - everything that's going to fly).

Seamless Weight Ranges

The THETA ULS was planned for Seamless (continuous) weight ranges, with no overlapping. These mean that any particular flying weight features in only one glider size. These THETA ULS Ideal Takeoff Weight ranges provide the best compromise between speed and climbing performance for all normal conditions, for each glider size.

Flying outside the Seamless Weight Ranges, in other words near the lower or upper certified weight limits, can alter a paraglider's flying behavior and handling, but without affecting your safety. Glide performance remains the same over a complete weight range, but climb performance is altered.



If the THETA ULS is flown outside its Seamless Weight Range, in the upper part of its Certified Weight Range, the higher wing loading will raise its trim speed and produce more dynamic and agile flying characteristics.

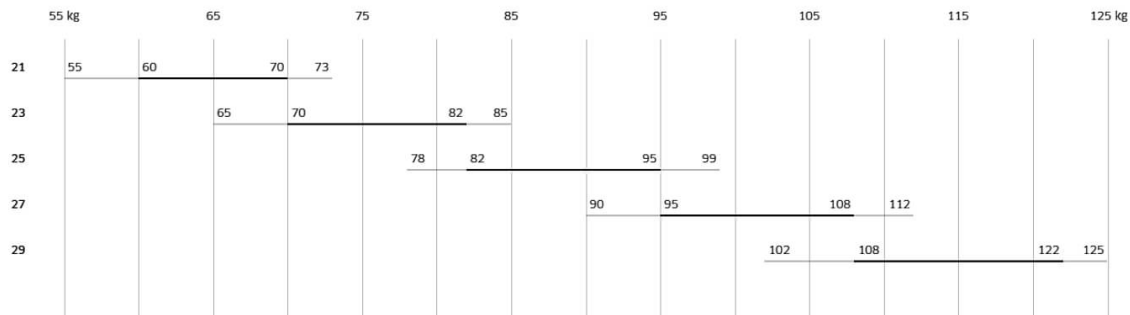

3.5. Flying with a wet paraglider (risk of deep stall)

Flying with a wet glider creates a risk of deep stall. Deep stall is often the result of a combination of factors. The weight of the wet canopy goes up, and this increased weight increases the angle of attack, which always puts the glider nearer the deep stall limit. Added to this, water drops on the top surface have a detrimental effect on the laminar flow of the boundary layer near the leading edge, which distinctly reduces the maximum lift coefficient. If the wet glider is also being flown at its lower weight limit there is a further small effect of increasing the angle of attack, as well as there being a lower airspeed because of the reduced wing loading.

In order to avoid the risk of deep stall with a wet glider, the wing should be braked as little as possible, and big ears not used at all. As a further preventative measure apply moderate (25-40 %) speed bar. These actions have a small effect in reducing the angle of attack. If the wet glider does go into deep stall you should recover by using the speed bar only. See also section "Deep stall".

3.6. Winching

The THETA ULS is suitable for winch launching. When taking off in windless conditions, ensure that the paraglider is laid out in an arched or even wedge shape (to avoid risk of the glider rosetting).

Winch launch is only permitted if:

- The pilot has completed a tow training course (only Germany/DHV).
- The winch system is certified for use with paragliders.
- The winch operator has been fully trained in paraglider winching.

3.7. Acrobatics

We do not recommend flying acro manoeuvres with the THETA ULS.

Be aware that dynamic manoeuvres put greater loading on the structure and can shorten the glider's life. This



means that a regular check of the paraglider is essential for your safety. In addition there will be the special requirements of your country to be observed.

3.8. Tandem flying

The THETA ULS is not certified for tandem flying.

3.9. Paramotoring

The THETA ULS is not certified for paramotoring.

4. GETTING STARTED

4.1. Delivery

Every ADVANCE paraglider has to be flown by the dealer before delivery to check for correct settings and trim. The dealer finally enters the date of the first flight on the type placard fastened on a rib at the centre of the wing. This entry confirms that defects in the product that can be attributed to manufacturing faults are covered by the ADVANCE warranty. Register your new ADVANCE product in your MyADVANCE account no later than 10 days after purchase to benefit from the extended ADVANCE warranty. More information under "Warranty".

4.1.1. Scope of delivery

The delivery of the THETA ULS includes a COMPRESSBAG ULS, a repair kit, a mini-windsock and a «Getting Started» booklet.



4.2. Basic settings



At delivery the basic set-up of the THETA ULS will be the trim settings that the ADVANCE test team found to be best. Certification was also gained in this condition. Any alterations or changes to the paraglider, such as altering the line lengths or fitting different risers or quicklinks, will result in a loss of the glider's certification.

Warning Do not modify your glider – it will no longer be certified.

Adjusting the brake lines

Leave the THETA ULS in its factory settings. The brake line lengths have been set for optimal handling, as established by our test team. The free travel of the brake lines makes sure that the trailing edge remains unbraked during takeoff, in fully accelerated flight and when using the C handles.

Warning The brake lines can shorten after some time.

Info We recommend a bowline knot for attaching the handles.

4.3. Speed system

Set the length of your speed lines so that you can use the full travel of the speed system.

Warning The speed system is correctly adjusted when you can use the full travel available on the risers. Make certain that the speed lines are not set too short, thus causing the wing to be pre-accelerated all the time!

5. FLIGHT CHARACTERISTICS

We recommend that you make your first flights with your new glider in quiet conditions, in a familiar flying area. A few pull-ups at an easy site will give you confidence in the THETA ULS's handling qualities, from the very beginning.

5.1. Takeoff

The THETA ULS takeoff behaviour is very smooth and easy for both forward and reverse takeoffs. The canopy inflates quickly and rises progressively, without hanging back.

The THETA ULS big ear lines have their own attachments. THETA ULS takeoff is achieved using the A-risers. The canopy fills reliably from the middle, and rises exceptionally straight with little effort.

The THETA ULS rises exceptionally easily, so it is very important that you match your pull-up technique to the weather conditions and the steepness of the slope. This means:

- In a lot of wind and/or on steep ground the THETA ULS needs little or almost no initial tug (□just lead it up□).
- In zero wind and/or on flat ground a more reasonable impulse would be sensible.

5.1.1. Connecting the Risers

The risers of your paraglider have the "Easy Connect System" compatible with ADVANCE harnesses, which helps you to connect the risers. Each riser has coloured sewing running up the back of the riser, red for left and blue for right, in the direction of flight. The coloured sewing facing the pilot, and the riser running cleanly upward to the lines confirm that the riser has not been connected with an 180 degree twist.

The "Easy Connect System" also enables you to clip in while facing the wing. This can be helpful for a reverse



takeoff in windy weather.



Video Tutorial: <https://www.youtube.com/embed/rQcNyx2FHTU>

5.1.2. Takeoff preparation and checks

Before every takeoff carry out the following pre-takeoff checks:

1. Harness and helmet buckled, reserve OK?
2. Lines free?
3. Canopy open?
4. Wind direction and strength assessed?
5. Airspace and field-of-view clear?

Hint

To get the wing in the right shape for takeoff do the following: pull the brake lines in while you are sorting the lines until the canopy arrives at the perfect banana shape.

Warning

Before each flight, check that the reserve handle is in the intended position and that the yellow locking cables of the reserve handle are correctly stowed.

5.1.3. Takeoff in light wind (forward takeoff)

The THETA ULS only needs a moderate pull-up impulse even in a light wind. It is not necessary to step back and 'run into the lines'. Guide the glider up with pronounced leaning forward, but without too much of a pull on the A-risers, until the canopy is overhead. During the pull-up phase any directional correcting should only be done by decisively moving under the wing, without using the brakes. After any necessary corrections and a satisfactory visual check a few determined steps with a good lean forward will achieve lift-off, even in little wind. Careful braking can shorten the takeoff run.

5.1.4. Takeoff in stronger wind (reverse takeoff)

The reverse takeoff is mainly recommended for stronger winds. During the pull-up you should walk towards the THETA ULS as necessary to control its rising rate. Turning round and taking off with the THETA ULS will then prove to be easy.

Hint

Playing with the glider on flat ground in some wind gives a good feeling for the wing. You can get to know the THETA ULS's characteristics very well, and try out takeoffs, stalling, shooting forward tendency and collapses - while remaining safely on the ground. The ADVANCE test team have a motto: one hour's ground training is worth 10 high flights. But bear in mind that ground practice puts use on the glider.

5.2. Normal flight

In calm air the THETA ULS's best glide is achieved with fully released brakes. Light braking brings the glider to its minimum sink condition. When flying into a headwind, through descending air, or when proceeding to the next thermal, glide performance will be distinctly improved by appropriate use of the speed system.

Despite the wing's high stability an active flying style is recommended - collapses can be almost completely avoided. This means keeping the lightly-braked glider directly above you; in other words, countering roll and pitch disturbances.

- When the angle of attack increases (e.g. wing swings back when entering a thermal) the brake lines should



be briefly released fully, until the glider returns to its overhead position.

- When the angle of attack reduces (e.g. glider shoots forwards) the wing should be briefly and strongly braked.

Be careful not to get below minimum speed, and don't overreact with the brakes.

5.3. Turning flight

The THETA ULS has short and precise brake travel when steering. It responds very directly and progressively to increasing steering inputs, as soon as the free travel in the brake lines has been taken up. Active weight shift effectively assists steering. Angle of bank can always be increased, stabilised or reduced by brake line load.

The THETA ULS makes a very agreeable companion in thermals. You do not have to correct for large pitching movements, and this improves your climbing behaviour – and therefore your performance – significantly. When thermalling, choose the desired angle of bank and corresponding radius, and try to let the glider turn steadily at this attitude. Outside brake should be used to steady the wing tip and, in particular, control the rate of turn. Anything stronger will slow the wingtip down and lose the glider's good steering qualities.

Warning To keep good manoeuvrability make sure to fly your THETA ULS with enough airspeed while turning in thermals – not too much outside brake.

Info If a brake line breaks the THETA ULS can be steered by careful use of the C-Handles.

5.4. Accelerated flight / C-Handles

The THETA ULS remains extremely stable even in accelerated flight. However, paragliders operate at a lower angle of attack while flying at their higher speeds, and the degree of stability is generally reduced. The higher aerodynamic forces involved at higher airspeeds mean that a collapse can be more dynamic (see also section "Collapses").

When encountering severe turbulence while flying accelerated, release the speed bar fully before applying the necessary stabilising brake. The THETA ULS's high degree of structural stability allows it to be flown in normally turbulent air while accelerated. Active speed bar should be employed for adjusting angle of attack under these conditions, instead of brake. Pitch attitude disturbances can be minimised in this way, and optimal glide performance can be maintained. See also section "Speed system".

When the angle of attack increases (e.g. wing pitches back when entering lift), briefly press the speed bar harder; when the angle of attack decreases (e.g. wing pitches forward), release the speed bar.

Warning Even though the THETA ULS is very stable in accelerated flight you should only use as much speed bar as you feel happy with!

Hint Make sure that brake is not applied at the same time as speed bar, otherwise you will find yourself in the worst possible gliding situation, without gaining any advantage.

Hint Always choose a suitable speed for best glide taking into account the actual headwind, sink rate (descending air) and expected next climb.

Using the C-Handles

The THETA ULS has a new easy C-handle System (neoprene-coated connection on the C-risers). It is possible to steer using these C-handles instead of the brake lines – from trim speed right up to 100% speed bar. Steering and



active flying using C-risers (handles) has less effect on performance than using the brakes for the same purpose: they brake the wing more efficiently than pulling the trailing edge down; so less speed is lost. Although they also work by increasing angle of attack this increase relative to speed is less than results from a normal brake input.

The use of C-handles is not necessary at trim speed, but you can use them for slight course corrections or turns. However, at fully-accelerated glide the C-handles become useful. They tell you very directly what is happening to the canopy. You can use them for active flying as they give immediate notice of impending canopy disturbance so you can prevent a problem at its onset in a way that only reduces performance slightly. At speed, steering is also very effective with the C-handles.

Grab around the C-risers with your whole hand and place your hand on the neoprene-coated C-handle connection. Important with the C-handles: Pull so that the B-riser is also pulled down. Make sure you have unwrapped your brakes first. By careful pulling then releasing you can oppose a forward pitch movement in light turbulence. In addition, you can also compensate for canopy pressure reduction e.g. as generally occurs before a collapse.



Info Learning efficient and instinctive C-handle technique needs much practice and experience. Try it out slowly.

Warning The C-handles should be operated with care and discretion. As with other paragliding activities too much and too abrupt pulling risks stalling.

Warning C-handle control is only recommended for gliding in calm or lightly turbulent air. In very turbulent conditions ADVANCE recommend releasing the speed bar (and the C-handles) and flying actively with brakes only.

5.5. Collapses

5.5.1. Asymmetric collapse

With an active flying technique in normal flying conditions, collapses can be almost completely prevented. The wing gives very precise canopy feedback and makes it possible to sense an impending collapse early on, thus



helping timely pilot reaction. Should a collapse occur the wing will fold in a predictable and progressive manner from wing tip towards the centre.

If the glider does, however, suffer an asymmetric collapse at trim speed, it will respond to collapses of 50 % or more with a slight turning tendency, allowing the heading to be easily maintained with light counter-steering. Normally, the wing will reopen without pilot action. With an asymmetric collapse in accelerated flight the wing will react more impulsively because of the higher forces associated with higher airspeed. The turning behaviour caused by a collapse at full speed is more dynamic, but can be well controlled.

If a collapse is slow to reopen, a deep but fast pull on the closed side brake will help. It is important to completely release the brake again to let the glider keep its flying speed. Be careful with the brake on the open side, and only apply enough to keep straight – so as not to stall the wing.

Poorly flown wingovers can cause a wingtip to fold inwards from the side, causing it to catch in the lines and create a cravat. Due to the high drag they produce cravats can lead to strong rotation (spiralling). Stop an increase in rotation rate by just the necessary amount of outside brake. Then open the cravated wingtip by pulling the orange stabilo line. Clearing a cravat can be also done more quickly by 'pumping'. The appropriate brake should be applied to 75 % brake travel within a maximum of two seconds, and then released immediately.

Warning If you want to make an accelerated collapse during safety training we recommend that you lead up to it slowly – starting with unaccelerated and then partially accelerated attempts.

5.5.2. Symmetric collapse (front collapse)

After a spontaneous or A-riser provoked collapse the airflow breaks away from the profile and the canopy will pitch back. The pilot swings back underneath after a short delay. Wait, without applying brake, until the wing is again above you and returns to normal flight. After a big collapse reopening may be delayed, but do not forcibly encourage reopening by the use of excessive brake, because of the risk of a full stall.

Warning When simulating a front collapse it is imperative that ALL A-risers are gripped and pulled down together.

Warning After a very impulsively provoked front collapse in accelerated configuration (for example during SIV training) it can happen that the front of the canopy does not open by itself. Help the wing to open with a brief brake impulse by pulling the brakes to 75% within one second, immediately and completely release them, then be prepared to control the forward surge.

5.6. Rapid descents

For quick and efficient ways of getting down the ADVANCE test team recommend big ears (with or without speed bar) or the spiral dive – the choice depends on the situation.

Hint Fast descents should be practised now and then in quiet conditions – so they won't become emergencies when you need them.

5.6.1. Symmetrical collapsing of the wingtips (big ears)

The THETA ULS big ear lines have their own attachments. To apply, pull the outer A-lines briskly downwards at the same time. The wingtips will fold, and can be easily held in this position. Sink speed can be increased by using the speed system while big ears are applied. Depending on the situation the glider can be steered using weight shift. To reopen, release both A-lines at the same time. Opening can be speeded up by a light pull (pump) on the brake. Open

9 / 23



the ears one at a time.

- Info** Big ears is also possible using two lines (per side) with the THETA ULS. Here it is important that the glider must be accelerated as well, and the trailing edge must not be braked! Attention the manoeuvre can be demanding.
- Warning** Do not fly spirals or sharp changes of direction with big ears applied; the increased loading carried by fewer lines can damage the structure.
- Warning** Be aware that flying with big ears brings the stall closer. Be careful with the brake lines when big ears are applied, and do not use this descent method if the wing is wet. See also the section "Flying with a wet paraglider"
- Hint** If you want to lose height as quickly as possible and fly away from a problem area at the same time we recommend the following: apply big ears and use as much speed bar as conditions allow.

5.6.2. Spiral dive

For the most comfortable way of doing this we recommend a neutral sitting position without active weight shift, and a shoulder-width carabiner distance (approx 45 cm).

Enter the spiral by progressively pulling one brake. Your head and field of view should be directed in the turn direction. As the angle of bank increases so will the rate of turn, airspeed and centrifugal force, which makes the pilot feel heavier.

The behaviour of the spiralling paraglider can be separated into two phases: in the beginning the glider makes a normal turn which progressively tightens, with increasing angle of bank. In the second phase the paraglider engages its spiral mode. This means that the wing dives forward and assumes a more vertical flightpath. During this phase of the manoeuvre try to keep a neutral sitting position and give way to the centrifugal force – your body will be pulled to the outside of the turn.



To recover keep the neutral sitting position and progressively release the inside brake. Your body weight will be somewhat tipped to the outside. While coming out of a spiral dive of high vertical and rotational speeds some assistance with outside brake is essential. Careful releasing of the inside brake will prevent the wing from recovering too quickly, thus pitching back excessively before diving in front if the turn stops with too much speed remaining. Make sure that you start the recovery with plenty of height above the ground. Generally speaking you should allow the same amount of time to recover as it took to enter the manoeuvre, but remember that the vertical speed will be higher, and much more height will be used!

Warning The THETA ULS only comes out of a spiral dive by itself if the pilot is in a neutral sitting position. From a steep spiral with a high sink rate – more than 14 m/s – recovery requires active outside brake with weight shift to the outside at the same time.

Warning Weight shifting to the inside of the turn results in increased acceleration and stable continued rotation. In this case, active counter-braking with simultaneous weight transfer to the outside of the turn is required to end the manoeuvre (push your body outwards).

Warning The THETA ULS is approved for harnesses in group GH (without rigid cross-bracing). Harnesses in group GX (with cross-bracing) or those with very low suspension points (carabiners) may drastically change the flying characteristics in a spiral.

Warning Do not fly spiral dives or aggressive changes of direction with big ears applied: the raised wing loading carried by fewer lines can damage the glider.

Warning After recovering from a spiral dive it could be that the pilot flies into turbulence that he has caused. Fly actively to prevent a collapse.

5.6.3. B-Stall

The whole paraglider structure and its profile shape would be severely strained by a B-stall. We recommend that you do not carry out B-stalls on a regular basis. If you do fly a B-stall the recovery requires that the B-lines are completely released without hesitation, so that normal flight is resumed within 2 seconds. B-stall is difficult for light pilots because of the high force required.

5.7. Stalling

5.7.1. One-sided stall (spin)

When circling tightly in a thermal the THETA ULS indicates clearly, by strongly increasing brake load, the risk of a stall. Even so, if a wing does stall you will feel a marked reduction of brake load on the inside of the turn. If this happens you must immediately release both brake lines, so that the THETA ULS can return to normal flight by itself.

If a wing stalls completely the paraglider will go into a spin / negative rotation. The THETA ULS will react dynamically, but will still be manageable by the less experienced pilot. Even so – depending on the situation from which the paraglider is allowed to fly again – the reaction can be quite vigorous (shooting forward with a raised risk of collapse). The canopy can be arrested while shooting forward by well-judged braking. Normal flight can then be resumed without a further collapse.

Hint Basically, in all out-of-control flight situations, but especially the onset of a one-sided stall, you should immediately release both brakes fully – hands up!

5.7.2. Full stall

Although the THETA ULS responds early to brake input it has very long brake travel, and very high brake load at

11 / 23



the stall point. This means a large safety margin for the pilot.

Entry into a full stall is achieved by progressively and symmetrically pulling down both brake lines. Forward speed reduces. Airflow and wind noise reduce.

After reaching minimum speed the paraglider first goes into a brief phase of parachutal stall. Then further brake will cause complete airflow breakaway, and the wing will fall back in full stall. The THETA ULS has a strong desire to fly again, but is easy to hold in the stall. A half wrap of the brakes is recommended to fly full stalls.

To recover, the canopy has to be pre-inflated. To do this the brakes should, at first, be released slowly and symmetrically, and only fully released when pre-inflation is complete. The THETA ULS then flies away relatively cleanly, without shooting forward too much.

Hint As a basic principle you should immediately and fully release both brakes in all out-of-control situations, then be prepared to control the resulting surge carefully.

5.7.3. Deep stall

Stable parachutal stall cannot be established, whether attempted by brake or B-stall.

In rain, or if the canopy is wet, the THETA ULS like all paragliders, is more vulnerable to parachutal stall. If the wet glider were to go into parachutal stall you should recover only by accelerating using the speed bar. See also the section "Flying with a wet paraglider".

5.8. Landing

Always make a proper landing circuit with a clearly defined final approach. As the ground approaches progressively increase brake to level the flight-path, before applying full brake to completely arrest the forward speed.

Warning Steep turn reversals lead to strong swinging of the pilot, and should not be done near the ground.

Warning Braking will reduce your speed and increase your sink rate, but it will certainly seriously restrict your ability to manoeuvre.

Warning Getting below minimum speed leads to stalling; this should unquestionably be avoided when top landing, and on final approach.

Info Never let your glider fall to the ground on its leading edge. The overpressure so caused inside the wing can rip the cell walls and damage the leading edge.

Info After landing in water the canopy can quickly fill up, and become very heavy. The canopy should be lifted out of the water by its trailing edge, giving the water a chance to run out. Otherwise it might tear under this unaccustomed heavy load.

6. FOLDING & PACKING

6.1. Packing basics



Careful folding and packing is crucial for the life of your THETA ULS and ensures that structural reinforcements are kept in the best possible condition..

Warning While folding, the glider fabric should not be dragged across the ground unnecessarily, or subjected to other mechanical stresses.

Warning The Nylon or Nitinol leading edge profile rods must always lie flat on top of each other and not be kinked when packing.

Info For folding assistance, the centre of an ADVANCE wing is also marked with a logo label at the trailing edge.

The following is a list of common packing systems and their comparisons in speed, handling and care quality.

6.2. Using a inner bag (e.g. COMPRESSBAG)

ADVANCE paragliders are supplied with a COMPRESSBAG (inner bag) as standard.

Hint First fold your glider to the width of the inner bag. Fold the result to match the length of the COMPRESSBAG.

Hint Regularly change your choice of centreline for the initial folding stage, so that the same areas are not always stressed.

Hint When at home, open the side zipper of the COMPRESSBAG so that the wing can relax and breathe while resting.

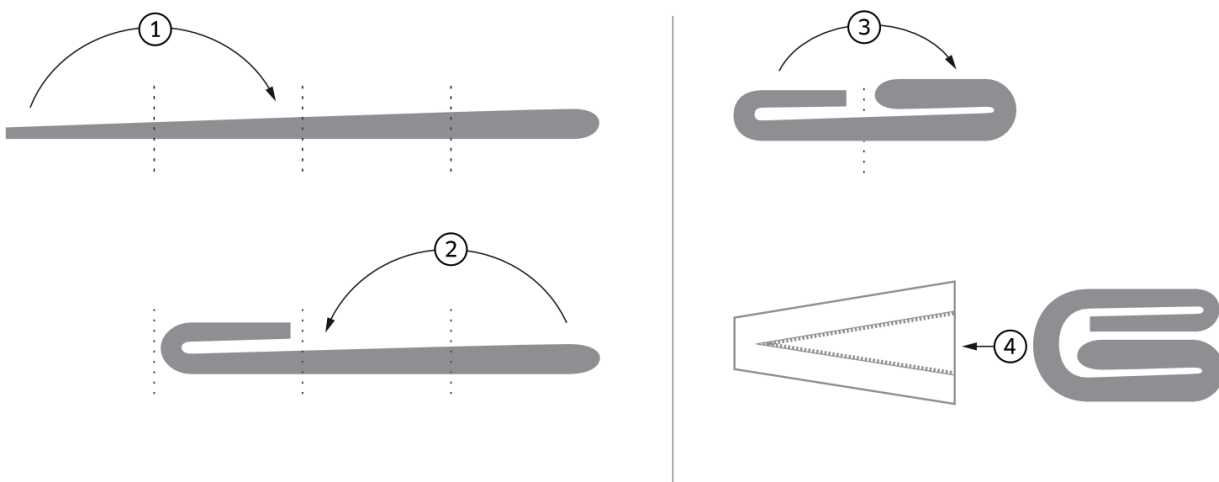

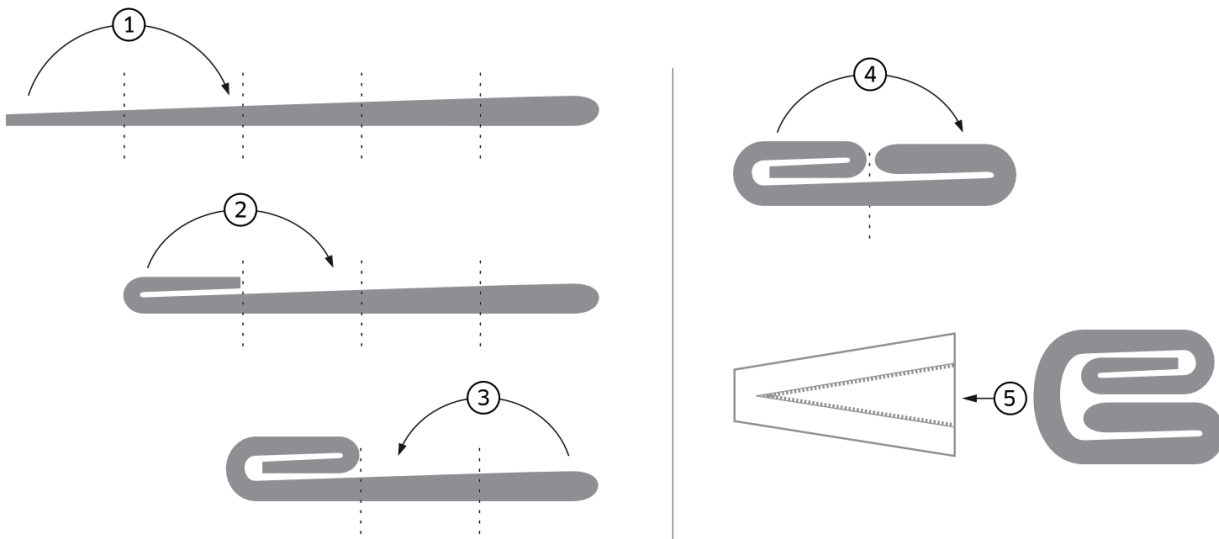

Videoanleitung COMPRESSBAG: <https://www.youtube.com/embed/eHeV2K-xeQU?si=HROEGRD8gatM09zm>

6.3. Using a cellular bag

Packing with a cellular bag is both gentle on the glider and easy to do. It avoids dragging the canopy over the ground. A tube bag retains the glider shape and improves its lifespan.

The corresponding product in the ADVANCE range is the TUBEBAG: www.advance.swiss/en/products/bags/100955

Hint

While at home, release the compression strap and store your glider in its unfolded TUBEBAG.



Videoanleitung TUBEBAG: <https://www.youtube.com/embed/fuQAvfX450?si=sSPRTdv5S6929k8W>

6.4. Using a compression cellular bag

In addition to the advantages of a classic cell packing bag, the FLATBAG ULS can be compressed to the maximum and goes perfectly with the LIGHTPACK ULS.

The corresponding product in the ADVANCE range is the FLATBAG: www.advance.swiss/en/products/bags/101008

Hint

When you get home, open the FLATBAG zipper and store your glider in the unfolded FLATBAG.



Videoanleitung FLATBAG ULS: <https://www.youtube.com/embed/Smpq1ux0HV0?si=na07h0SpAWezKzK>

7. MAINTENANCE & CARE

7.1. Storage



**DON'T STORE
WET**



**AIR PERIODICALLY
OR STORE OPEN**

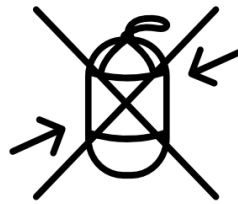

**DON'T STORE
COMPRESSED**

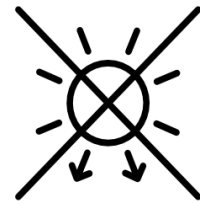

**DON'T LEAVE IT
UNNECESSARILY
IN THE SUN**

Ultraviolet light, heat, humidity, sea water, aggressive cleaning agents, unsuitable storing and physical abuse (□ dragging across the ground□) speed up the ageing process.

Hint Always store your paraglider uncompressed in a dry and dark place.

Hint Allow a wet or damp glider to dry by leaving it completely unpacked at room temperature, or outside in the shade.

7.2. Maintenance

7.2.1. Cleaning



**DO NOT USE
SOLVENTS FOR
CLEANING**

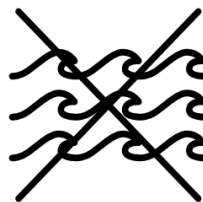

**AVOID
SEAWATER**

All rubbing and sliding action speeds up the paraglider fabric ageing process. The PU-coated nylon cloth is dirt-resistant anyway.

If your glider gets heavily soiled with dirt, grass stains, grease, cow dung, mold, resin or other dirt, just clean the fabric with a soft, damp cloth. Then allow the glider to dry thoroughly before packing it away.

15 / 23



It is best to use baby powder gently on adhesive residues.

Hint Clean the glider only with fresh water. Do not use solvents under any circumstances.

Hint If the glider gets wet with salt (sea) water rinse it thoroughly with fresh water.

7.2.2. Visual Inspection

Like any flying device, every paraglider should be routinely inspected by its pilot so that any damage to canopy, suspension points, lines, risers, etc. can be quickly detected and repaired. See chapter Repairs. Especially after a tree landing, or when the canopy has been dragged over the ground, the paraglider must be visually inspected in detail for damage, before it flies again.

7.2.3. Brake lines

Wraps & Twists

Each time a pilot takes a brake line wrap, that line is twisted. Metal swivels inserted between the handle and brake line can release this twist to some extent, but only partially, and routine flight with twists encourages a permanently twisted 'set' in a brake line. Some ADVANCE light gliders do not have metal swivels. Check your brake lines regularly for twists and untwist them, so that they naturally lie straight when unloaded.

Warning In extreme cases, a brake line with multiple wraps can shorten by several centimetres in flight, thus affecting the stall behaviour of the paraglider.

Hint Our development team recommends that you actively untwist (unwrap) your brake lines regularly in flight.

Damage

A damaged brake line, indicated by abrasion or parting of its cover, must be replaced immediately, together with its partner on the other side. The brake lines of all ADVANCE products are standardised and can be ordered as spare parts. Instructions for attaching brake lines can be found in the appendix under "bowline knots".

Hint If a brake line shows repeated damage in the same place, its pulley or low friction ring should be checked for rough spots.

7.2.4. Drain dust and dirt

The THETA ULS has a continuous, cross-cell dirt drainage channel with openings in the trailing edge. Foreign objects collected in the channel, such as dust, sand etc. are automatically "airflowed" out during flight. Larger foreign objects must be actively shaken out on the ground.

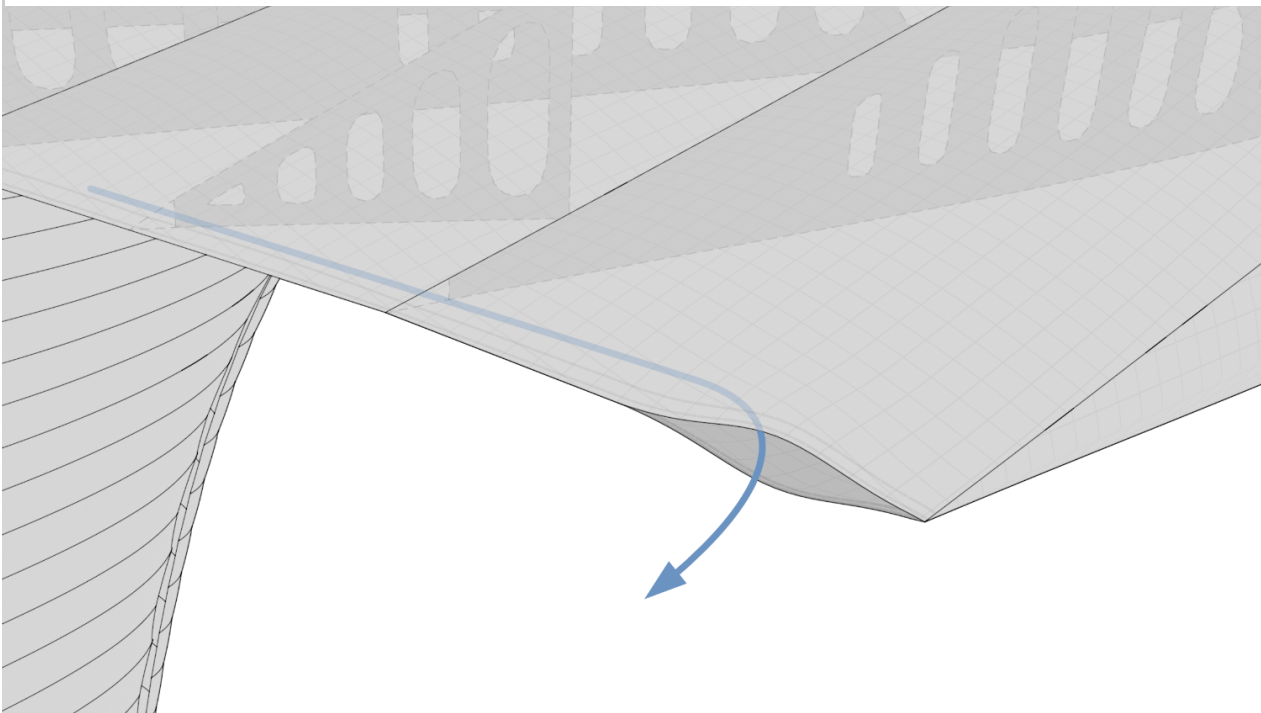

7.2.5. Wear sites

Speed system guides on the risers

If the paraglider is frequently flown accelerated the riser shortening lines may show signs of wear at their pulleys - fraying or chafing. If this is noticed, the line must be replaced by a specialist dealer. This action would also be taken during a periodic inspection, if necessary.

Riser quick-link locks (plastic triangles)

Replacement plastic clips for empty riser quick-link triangles can be ordered as spare parts and easily installed by the user.

7.3. Glider inspection

Your THETA ULS must be checked every 24 months, 100 flying hours or 100 flights, whichever comes first. The check should be carried out by an authorised -ADVANCE check centre, according to the recommended guidelines.

When carrying out a periodic glider inspection, the condition of all materials is assessed with the utmost care according to strict guidelines. At the end of the inspection, the overall condition of the paraglider is rated and recorded in a test report. If these guidelines are not observed, the extended ADVANCE warranty becomes null and void.

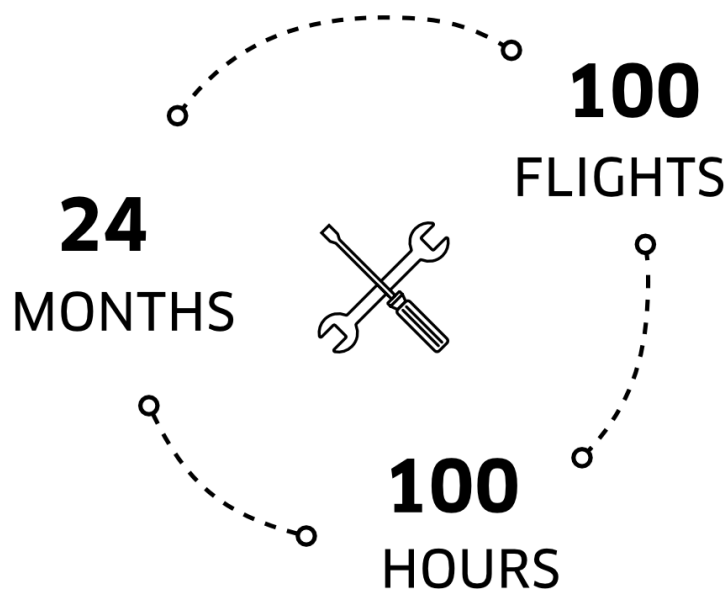

7.4. Repairs

Repairs in general

A paraglider is a lifting surface of complex construction. Seams and lines have been made with great precision. In general, therefore, an unauthorised individual should not carry out paraglider repairs. Only the manufacturer or an authorised Service Organisation should replace components with identical parts, or refit complete cells.

Small repairs become exceptions to this principle. Examples could be repairs to small tears or holes with self-adhesive Ripstop material, or replacing lines. In every case of repair or line change the paraglider must be pulled up on the ground before its next flight, and visually checked.

Your paraglider is delivered with a repair kit containing self-adhesive Ripstop. Other parts, such as lines, quicklinks, softlinks or risers can be obtained from your ADVANCE dealer, an ADVANCE Service Center or direct from ADVANCE. Addresses are on www.advance.swiss.

Canopy Repairs

Tears up to 3 cm in length, and very small holes that do not meet a seam, can be patched with the self-adhesive Ripstop from your repair kit. Make sure that the patch is cut out in a round or oval shape, and is big enough to generously overlap the damage. The similar piece of sticky Ripstop on the inside of the repair should be of a different size.

Line repairs

A damaged line must be changed, without exception. The easiest option is to go to an ADVANCE Service Centre or your ADVANCE dealer. Alternatively you can order the specific replacement line direct from ADVANCE or an ADVANCE dealer and fit it yourself. All the addresses are on: www.advance.swiss. Under "Service" on www.advance.swiss there are detailed instructions for identifying your line so that you can order it, and then fit it correctly on the wing.

What to do if the leading edge gets damaged?



If a leading edge wire breaks or its seam rips the glider must be taken to an ADVANCE checking facility where the wire can be replaced or sewn back in. To guarantee a long lifespan it is important that the wing is not allowed to fall on its leading edge after landing, otherwise the fabric can be damaged by abrasion. But mainly there is a risk, as in all paragliders, that the crossports could tear.

7.5. Disposal

Environmental protection plays an important role in the selection of materials and the manufacture of an ADVANCE product. We use only non-toxic materials and fabrics that are subjected to continuous quality and environmental impact assessments. When your equipment reaches the end of its useful life, please remove all metal parts (recycling) and dispose of straps and material in the designated facilities.

8. SERVICE & WARRANTY

8.1. ADVANCE Service Center

ADVANCE operates two company-owned service centres that carry out checks and repairs of all types. The workshops based in Switzerland and France are official maintenance operations, which have many years' experience and in-depth product-specific expertise. The ADVANCE worldwide service network includes other authorised service centres that provide the same services. All service facilities use original ADVANCE materials exclusively. You can find all information on checks and repairs and the relevant addresses at www.advance.swiss.

8.2. Support (Website)

At www.advance.swiss you will find detailed information about ADVANCE and our products as well as contact details for any questions you may have.

You also have the opportunity to register your product online up to 10 days after purchase in order to enjoy the full benefits of the ADVANCE warranty. You can also:

- Keep yourself updated about new safety-related findings about ADVANCE products.
- Download an application form for the check at ADVANCE as a PDF in order to be able to send in your product.
- To find an answer to a burning question under FAQ (frequently asked questions).
- Subscribe to the ADVANCE newsletter to receive regular e-mail updates about new products and services.

8.3. Online Account

Set up a MyADVANCE account at www.advance.swiss/warranty and register your product directly online after purchase.

In the MyADVANCE account you will find all documents for your product as PDF, e.g. the manual, security updates and much more. You can also view spare parts for your product and make support requests directly.

8.4. Warranty

As part of the ADVANCE warranty, we undertake to rectify any defects in our products that are attributable to manufacturing faults. In order for a warranty claim to be made, ADVANCE must be notified immediately on discovery of a defect, and the defective product sent in for inspection. The manufacturer will then decide how a possible manufacturing fault is to be rectified (□repair, replacement of parts or replacement of the product□). Basically, the legal warranty obligations of your country apply. If you register your product for free on our website within 10 days of purchase you receive an extended warranty of 12 months beyond the legal warranty period of

19 / 23



your country!

Warranty and Service Intervals begin from the date of the glider's first flight, recorded on the identification plate. If no date is evident the applicable date is that on which the glider was transferred from ADVANCE to the ADVANCE dealer. The ADVANCE warranty does not cover any other claim. Claims in respect of damage resulting from careless or incorrect use of the product (e.g. inadequate maintenance, unsuitable storage, overloading, exposure to extreme temperatures, etc.) are expressly excluded. The same applies to damage attributable to an accident or normal wear and tear.

9. TECHNICAL DATA

9.1. Data

THETA ULS		21	23	25	27	29
Flat surface	m2	21.52	23.33	25.42	27.33	29.13
Projected surface	m2	18.26	19.80	21.58	23.20	24.73
Certified takeoff weight	kg	55-73	65-85	78-99	90-112	102-125
Ideal weight range	kg	60-70	70-82	82-95	95-108	108-122
Glider weight	kg	3.10	3.35	3.55	3.80	4.00
Span	m	10.79	11.23	11.73	12.16	12.55
Projected span	m	8.55	8.91	9.30	9.64	9.95
Aspect ratio		5.41	5.41	5.41	5.41	5.41
Projected aspect ratio		4.01	4.01	4.01	4.01	4.01
Max. chord	m	2.44	2.54	2.66	2.75	2.84
Number of cells		59	59	59	59	59
Certification		EN/LTF B	EN/LTF B	EN/LTF B	EN/LTF B	EN/LTF B

9.2. Materials

We continuously review and test the variety of materials on offer. Like all ADVANCE products, the THETA ULS has been designed and manufactured according to the latest findings and processes. We have chosen the materials very carefully and with the strictest quality requirements in mind.

Leading edge	Skytex 32 universal
Upper surface	Skytex 27 classic II
Lower surface	DOKDO 10DSF
Profiles	Skytex 32 hard finish, Skytex 27 hard finish
Unsuspending profiles	Skytex 27 hard finish
Diagonals	Skytex 40 hard finish, Skytex 32 hard finish, Skytex 27 hard finish
Tension tapes	Skytex 32 hard finish
Main lines	A-8001-230, -190, -130, -090
Gallery lines	A-8001-130, -090, -070, -050
Stabilo	PPSLS 125
Brake lines	A-8001-050, -070
Steering lines	A-8001-190, A-7850-240
Risers	PES/Technora 7mm
Softlinks	Softlink DC 300



9.3. Certification

9.3.1. Category

The THETA ULS has EN/LTF B certification. The test reports can be downloaded from www.advance.swiss.

Certification ratings can only provide limited information about a paraglider's flying behaviour in thermally active and turbulent air. The certification grading is based primarily on induced extreme flight manoeuvres in calm air.

During the development of an ADVANCE paraglider, the emphasis is first and foremost on flying behaviour and handling, and not exclusively on the certification test. The result is a well-rounded product with the familiar ADVANCE handling. Nevertheless, the certification rating occupies a significant proportion of the specifications that have to be met.

9.3.2. Light sport aircraft

The THETA ULS belongs to the "Light sport aircraft" category with an empty weight of less than 120 kg.

10. APPENDIX

10.1. Components overview

10.1.1. Paraglider

1. Nameplate
2. Air intakes
3. Lower surface
4. Upper surface
5. Cells
6. Winglet
7. Cleaning velcro

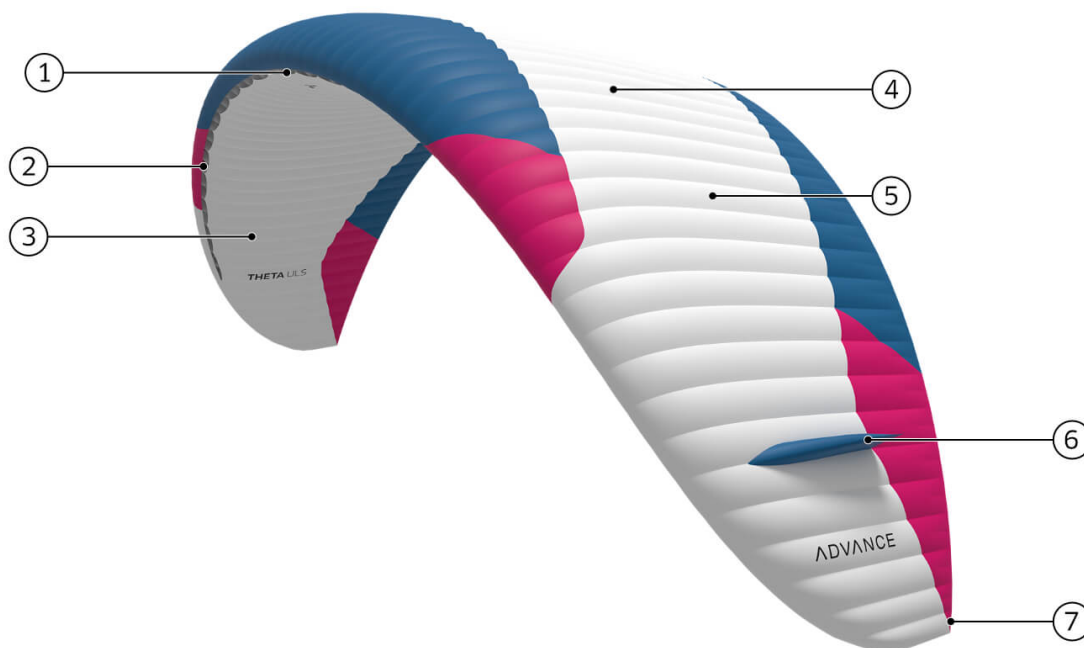

10.1.2. Risers



1. Split A-risers
2. Softlinks
3. Ceramic rings
4. Poppers
5. Swivel
6. C-Handle
7. Speed system pulleys
8. Brummel hooks

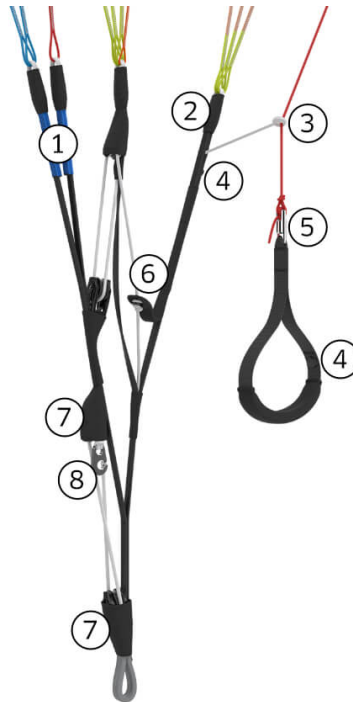

10.1.3. Line plan

Lineplan THETA ULS

10.2. Assembly instructions Softlink

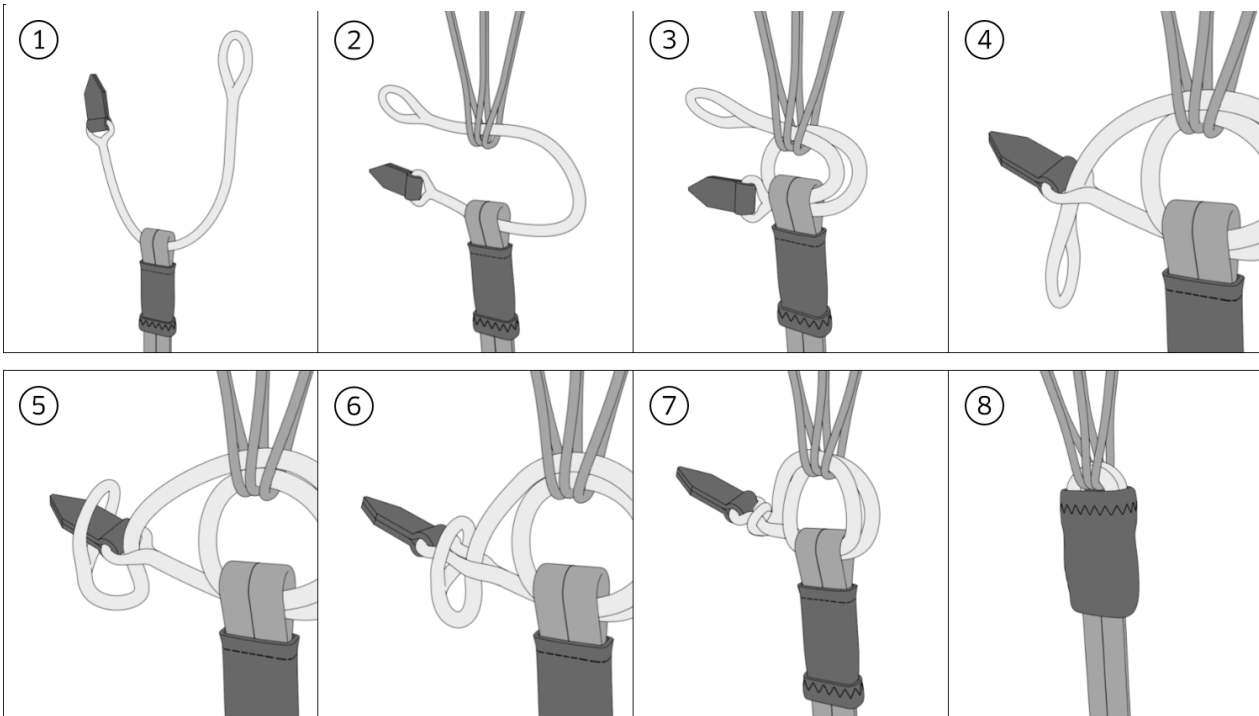

Video Tutorial Softlink: <https://www.youtube.com/embed/foMLOYmtkV8>

10.3. Mounting instructions brake lever

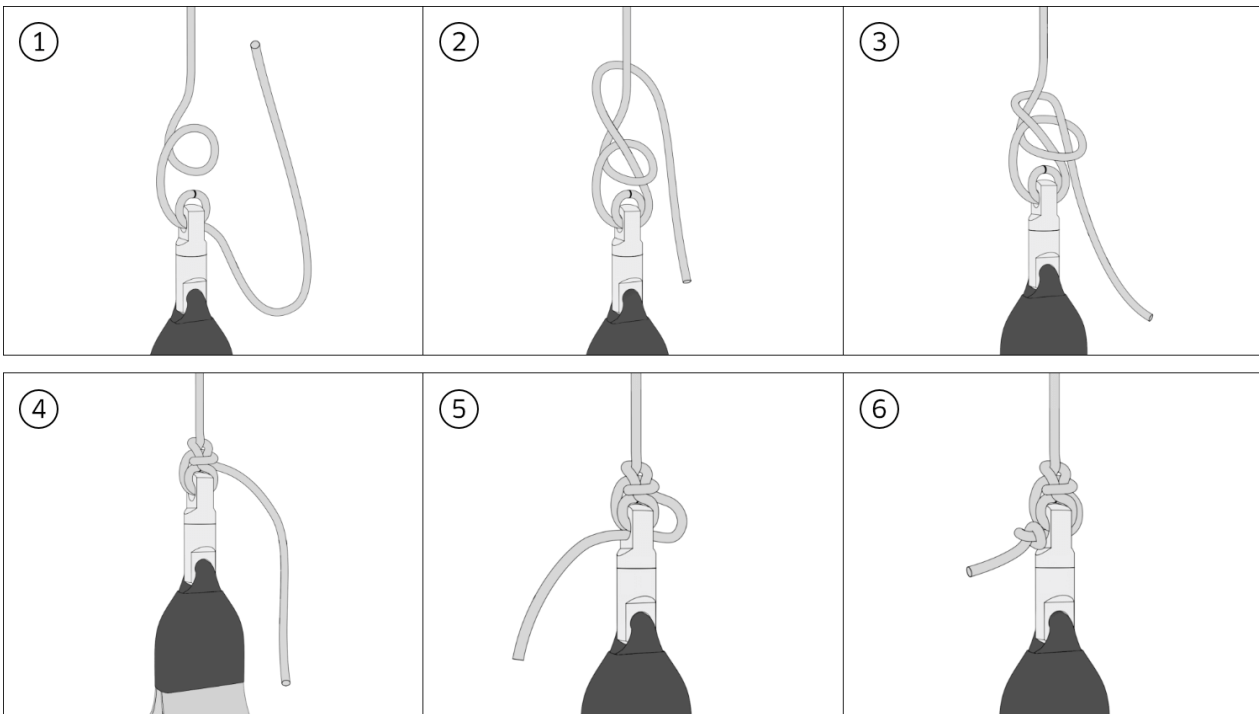

Video Tutorial Palstek: <https://www.youtube.com/embed/GTCOW2CivOk>